

**TOP VIEW**

**GENERAL NOTES:**

- CONCRETE 28 DAY COMPRESSIVE STRENGTH FC: 4000PSI
- REBAR #4 ASTM A-615 GRADE 60
- DL: 36" EARTH COVER
- LL: 25 SNOW
- SOILS: 2000PSI
- WATER PRESSURE: 62.4PSF
- FLEXIBLE PIPE ADAPTER PRESS SEAL 4" CAST-A-SEAL
- JOINT MATERIAL MEETS FEDERAL SPECS. SS-S-0021
- RISERS AS REQUIRED
- FIBERFORCE 750 REQUIREMENTS SHALL MEET THE REQUIREMENTS OF ASTM C1116, SECTION 4.13 AND NOTE 2. DOSAGE SHALL BE 5 POUNDS PER CUBIC YARD
- WEIGHTS: BASE=11,670 LB LID=2,075 LB

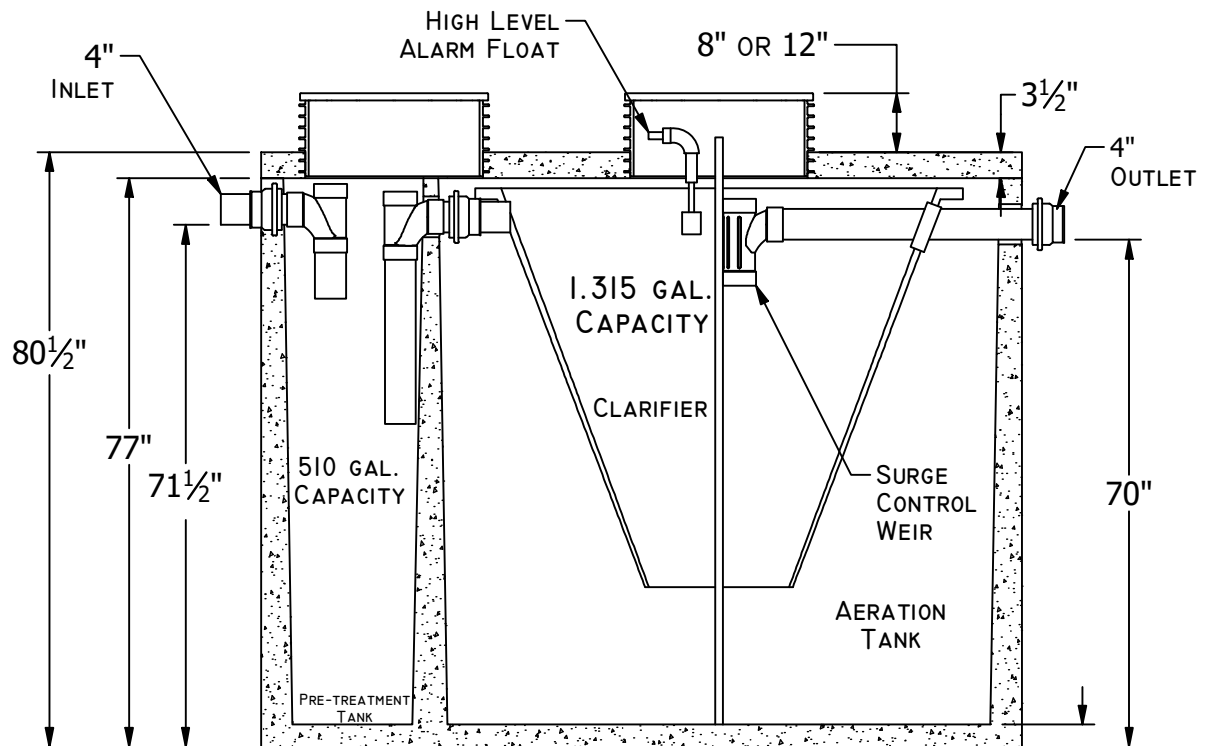

**FRONT SECTIONAL VIEW**