

19604 67TH AVE NE ARLINGTON, WA 98223  
 (360) 435-5531 WWW.CUZCONCRETE.COM

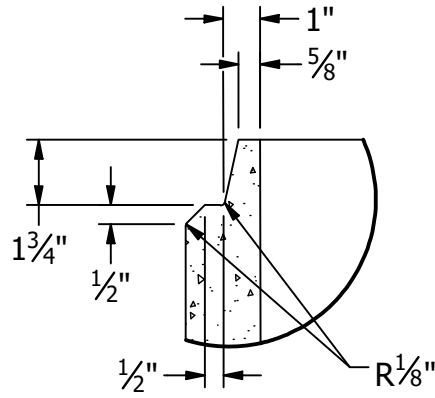

**DETAIL B**

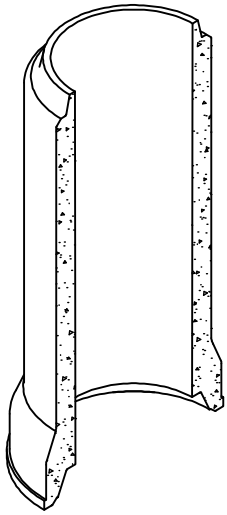
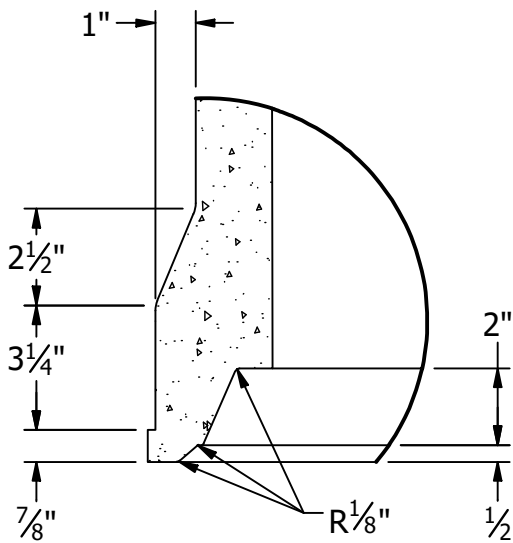

**DETAIL C**

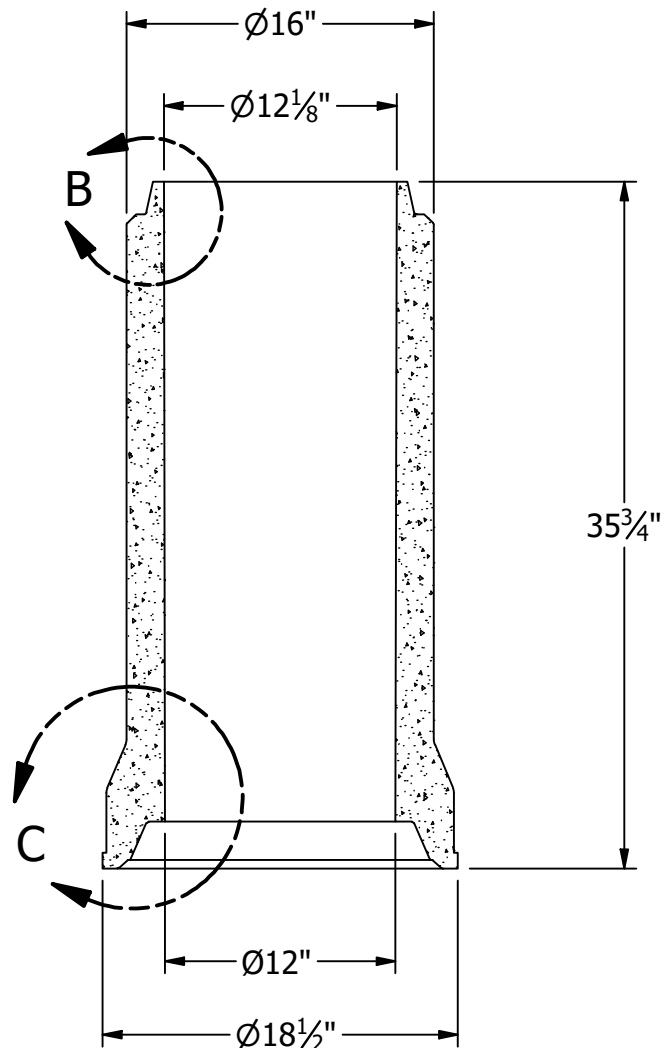

**FRONT SECTIONAL VIEW**

**GENERAL NOTES:**

- WEIGHT: 300 LB
- CONCRETE 28 DAY COMPRESSIVE STRENGTH  $F_c$ : 4000PSI
- REBAR #4 ASTM A-615 GRADE 60
- DL: 36IN EARTH COVER
- LL: 25 SNOW
- SOILS: 2000PSI
- WATER PRESSURE: 62.4PSF