

19604 67TH AVE NE ARLINGTON, WA 98223  
 (360) 435-5531 WWW.CUZCONCRETE.COM

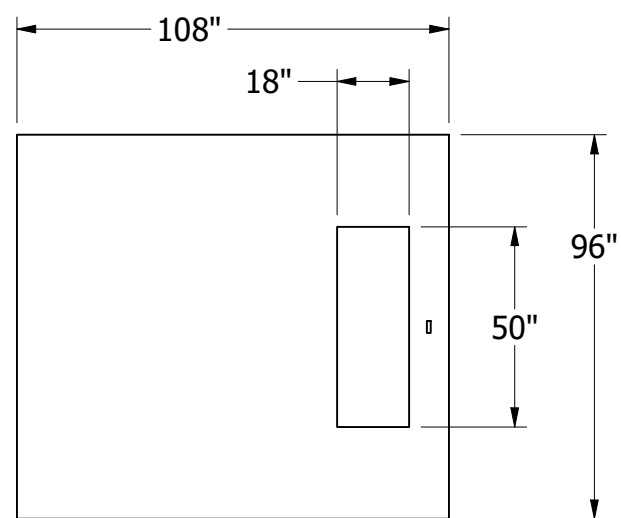
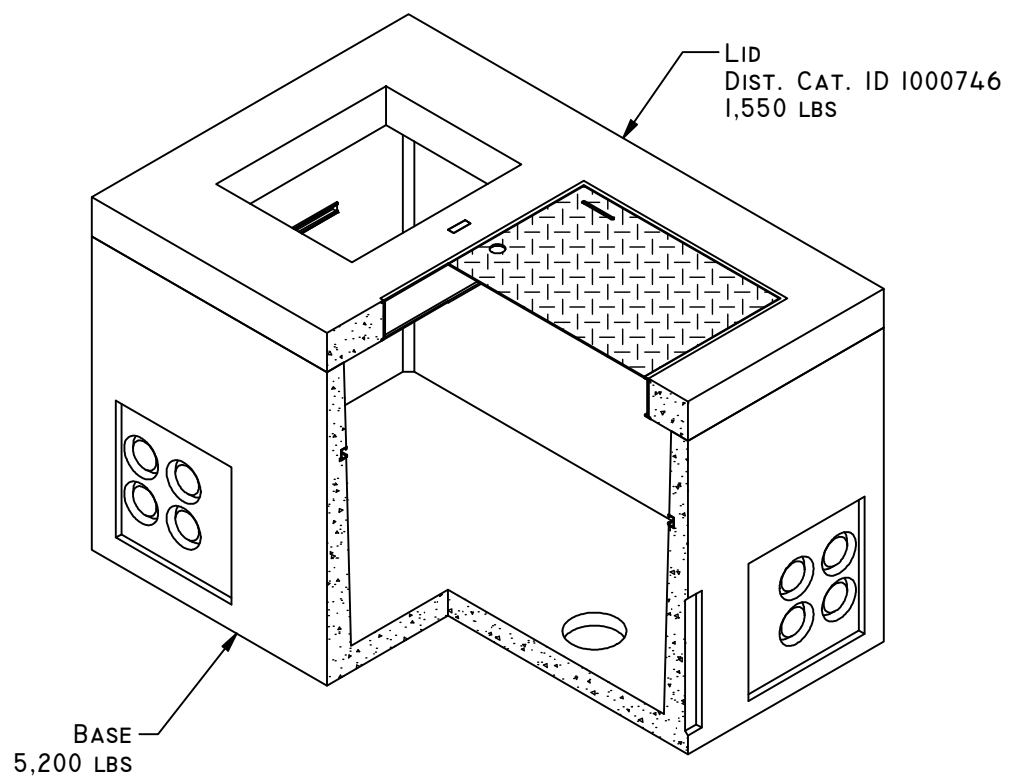

**OPTIONAL LID**  
 DIST. CAT. ID 1001689  
 5,050 LBS

**GENERAL NOTES:**

- TOTAL WEIGHT: 6,750 LBS
- CONCRETE: 28 DAY COMPRESSIVE STRENGTH FC: 4500PSI PER ASTM C-33 AND C-150
- REBAR: #4 ASTM A-615 & A-123 GRADE 60
- MESH: ASTM A-185 GRADE 88
- DESIGN: ASTM C-857 MINIMUM STRUCTURAL DESIGN LOADING FOR UNDERGROUND PRECAST CONCRETE UTILITY STRUCTURES
- HATCHES PER DISTRICT SPECIFICATIONS
- LOADS: SUITABLE FOR H-20 WHEEL LOADS IN OFF STREET LOCATIONS WHERE NOT SUBJECT TO HIGH DENSITY TRAFFIC
- REINFORCING PLACEMENT: 4X4 - 4GUAGE THROUGHOUT BASE, #4 IN CORNERS AND EDGES, 3 - #4 BAR EACH WAY IN LIDS
- JOINT MATERIAL: MEETS FEDERAL SPECIFICATIONS SS-S-00210, AASHTO M-1988 AND ASTM C990

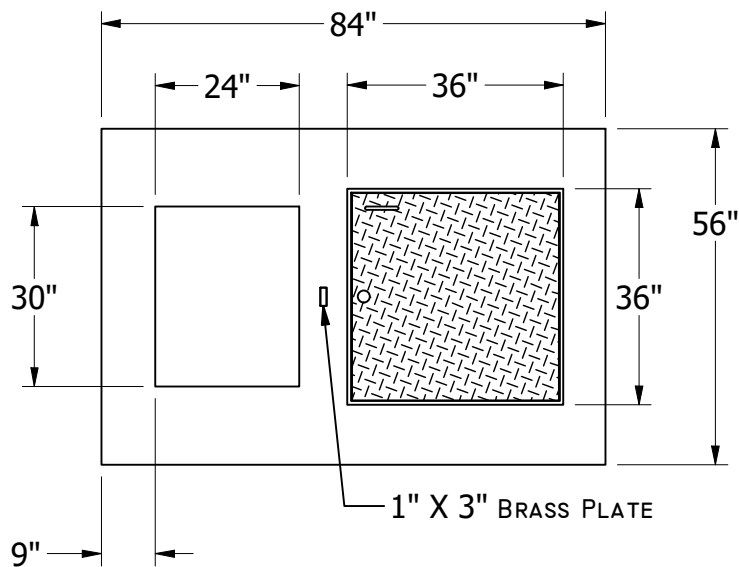

TOP VIEW

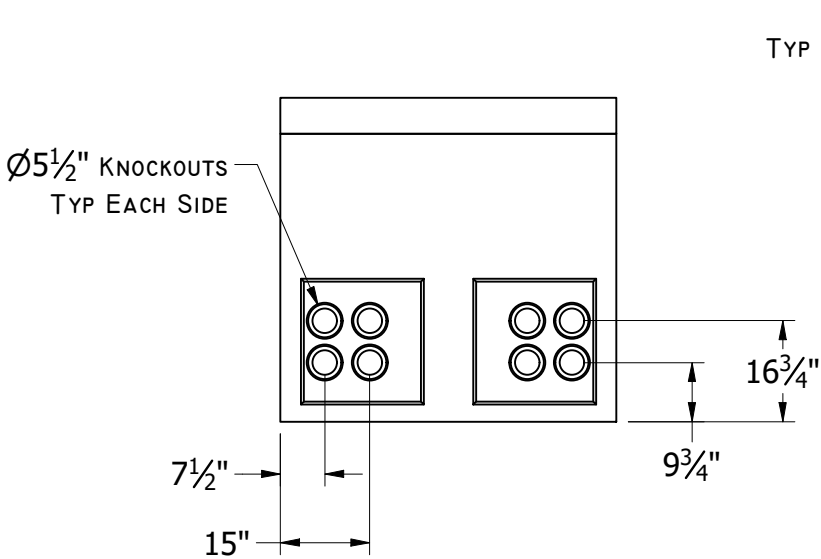

LEFT VIEW

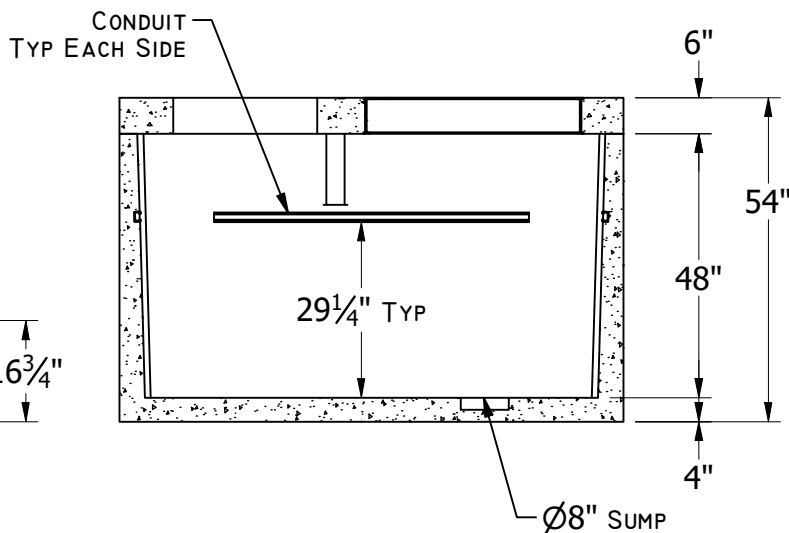

FRONT SECTIONAL VIEW