

**TOP VIEW**  
 LID OMITTED FOR VISIBILITY

**GENERAL NOTES:**

- TOTAL WEIGHT: 4,750 LBS
- CONCRETE: 28 DAY COMPRESSIVE STRENGTH FC: 4500PSI PER ASTM C-33 AND C-150
- REBAR: #4 ASTM A-615 & A-123 GRADE 60
- MESH: ASTM A-185 GRADE 88
- DESIGN: ASTM C-857 MINIMUM STRUCTURAL DESIGN LOADING FOR UNDERGROUND PRECAST CONCRETE UTILITY STRUCTURES
- HATCHES PER DISTRICT SPECIFICATIONS
- LOADS: SUITABLE FOR H-20 WHEEL LOADS IN OFF STREET LOCATIONS WHERE NOT SUBJECT TO HIGH DENSITY TRAFFIC
- REINFORCING PLACEMENT: 4X4 - 4GUAGE THROUGHOUT BASE, #4 IN CORNERS AND EDGES, 3 - #4 BAR EACH WAY IN LIDS
- JOINT MATERIAL: MEETS FEDERAL SPECIFICATIONS SS-S-00210, AASHTO M-1988 AND ASTM C990

Ø5 1/2" KNOCKOUTS  
 TYP EACH SIDE

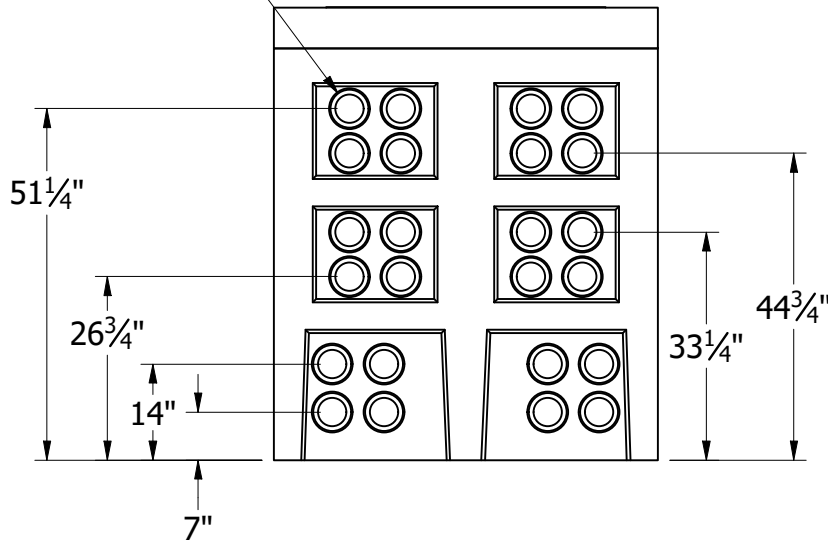

**LEFT VIEW**

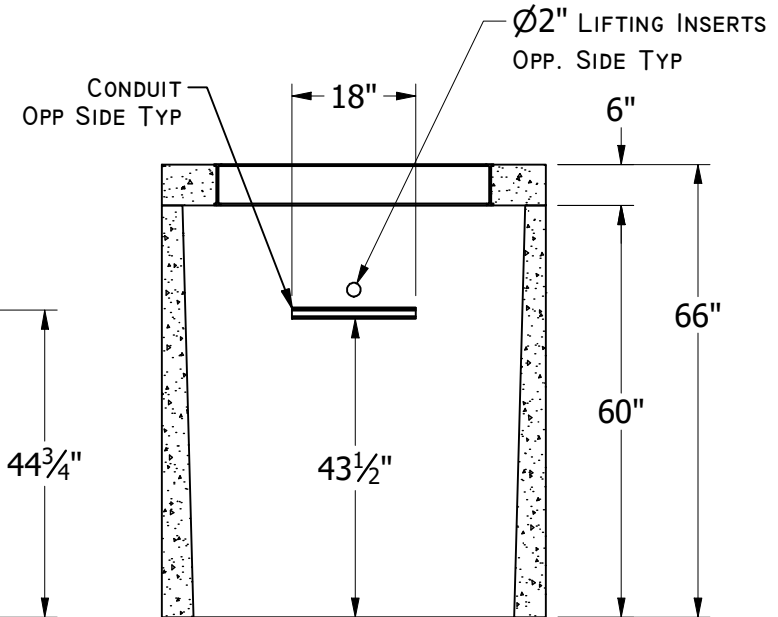

**FRONT SECTIONAL VIEW**