

19604 67TH AVE NE ARLINGTON, WA 98223
 (360) 435-5531 WWW.CUZCONCRETE.COM

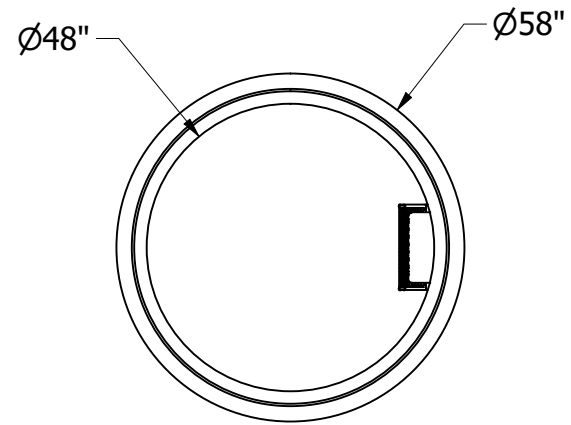

TOP VIEW

H	Weight (lb)
1'	1150
2'	2050
3'	3150
4'	3900

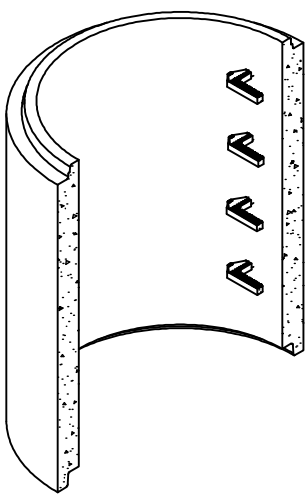
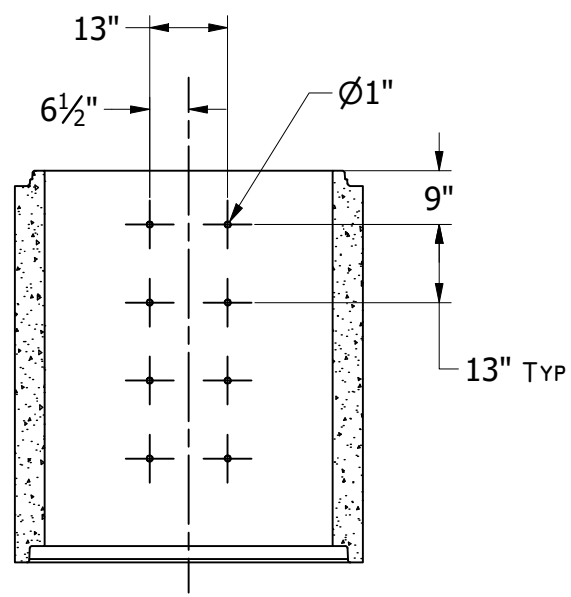

LADDER DETAIL
 STEPS OMITTED FOR VISIBILITY
 DIMENSIONS TYP
 SECTION C-C

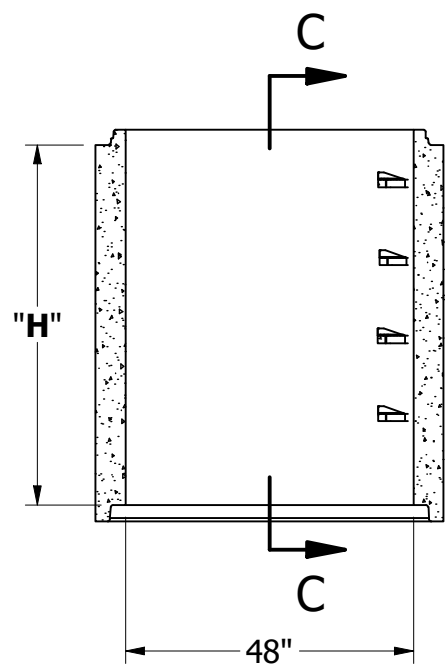

FRONT SECTIONAL VIEW

- GENERAL NOTES:**
- CONCRETE 28 DAY COMPRESSIVE STRENGTH FC: 4000PSI
 - AREA OF STEEL: .12 IN²
 - REBAR #4 ASTM A-615 GRADE 60
 - DL: 36IN EARTH COVER
 - LL: 25 SNOW
 - SOILS: 2000Psi
 - WATER PRESSURE: 62.4PSF
 - FLEXIBLE PIPE ADAPTER PRESS SEAL 4IN CAST-A-STEEL
 - JOINT MATERIAL MEETS FEDERAL SPECS. SS-S-002I