

TOP VIEW

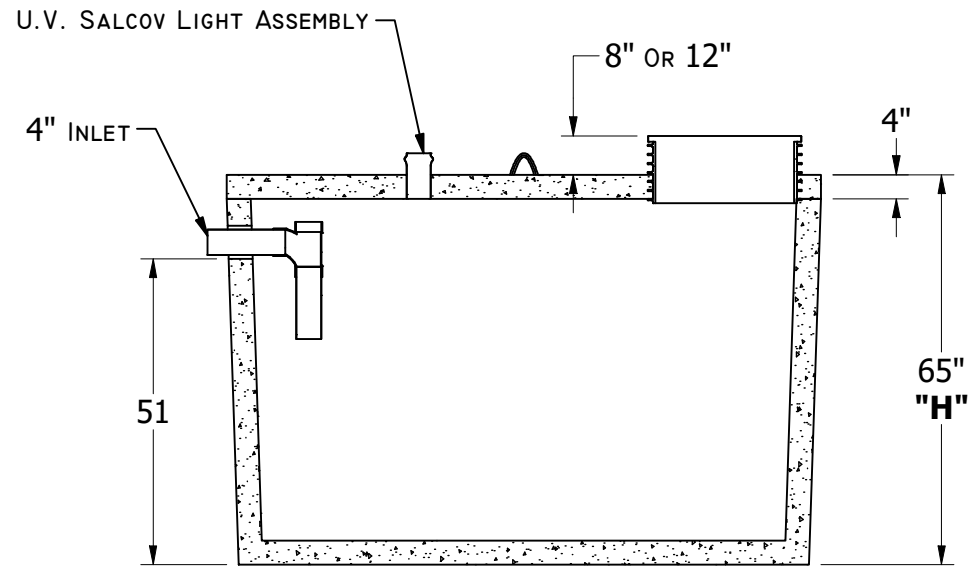

FRONT SECTIONAL VIEW

GENERAL NOTES:

- GALLONS PER INCH: 20.89
- TOTAL WEIGHT: 10,017LB
- ALL DIMENSIONS IN INCHES
- IF H2O TRAFFIC LID IS INSTALLED HEIGHT (H) IS RAISED 4IN
- CONCRETE 28 DAY COMPRESSIVE STRENGTH FC: 4000PSI
- REBAR #4 ASTM A-615 GRADE 60
- DL: 36IN EARTH COVER
- LL: 25 SNOW
- SOILS: 2000PSI
- WATER PRESSURE: 62.4PSF
- FLEXIBLE PIPE ADAPTER PRESS SEAL 4IN CAST-A-STEEL
- JOINT MATERIAL MEETS FEDERAL SPECS. SS-S-002I
- RISERS AS REQUIRED