

19604 67TH AVE NE ARLINGTON, WA 98223  
(360) 435-5531 WWW.CUZCONCRETE.COM

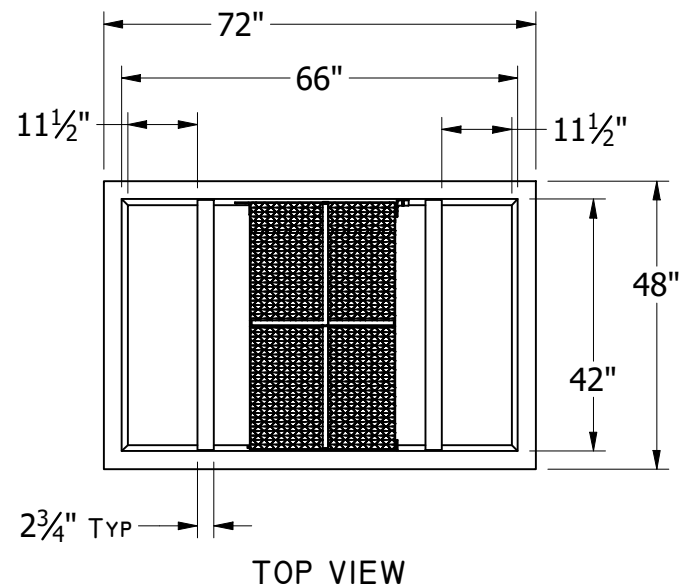

**GENERAL NOTES:**

- APPROX. WEIGHT: 8,094 LB
- CONCRETE: 28 DAY COMPRESSIVE STRENGTH FC: 4500PSI
- REBAR: #4 ASTM A-615 GRADE 60
- MESH: ASTM A-185 GRADE 88
- DESIGN: ASTM C-857 "MINIMUM STRUCTURAL DESIGN LOADING FOR UNDERGROUND PRECAST CONCRETE UTILITY STRUCTURES"
- LOADS: H-20 TRUCK WHEEL WITH 30% IMPACT PER AASHTO
- REINFORCING PLACEMENT: 4X4 - 4 GAUGE THROUGHOUT WITH 2 - #4 BARS ALONG BELL JOINTS
- HATCHES PER DISTRICT SPECIFICATIONS
- JOINT MATERIAL: MEETS FEDERAL SPECIFICATIONS SS-S-00210, AASHTO M-1988 AND ASTM C990
- TRAFFIC RATED RISERS AS NEEDED

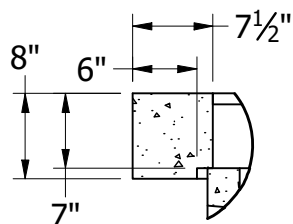
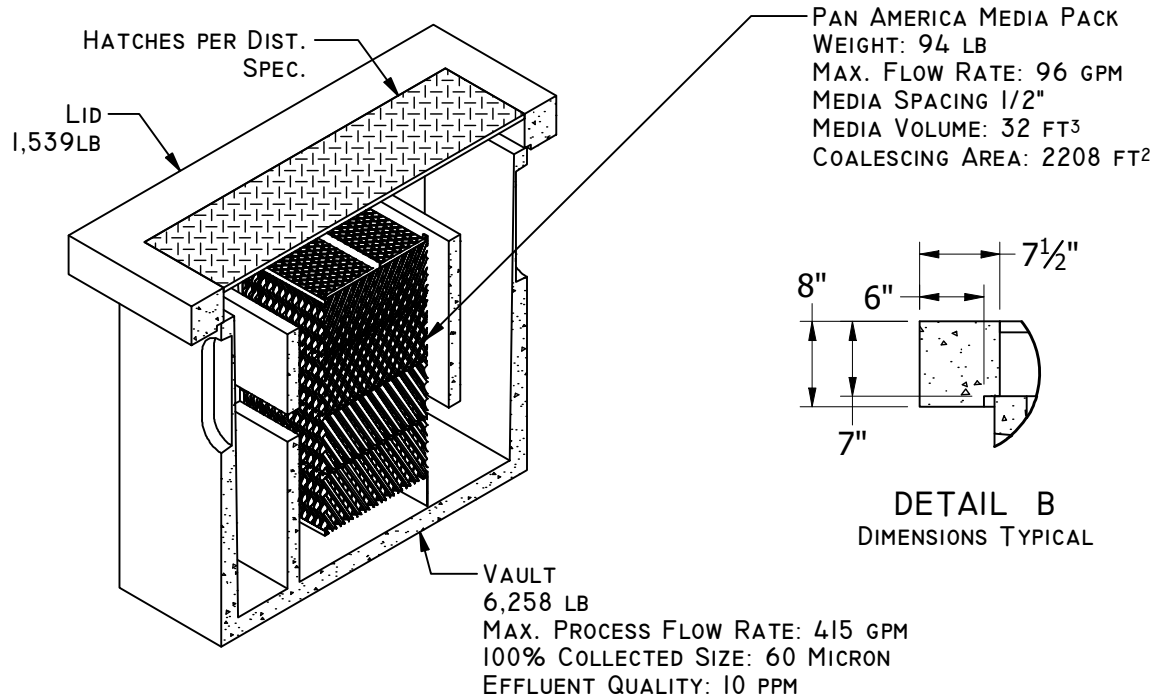
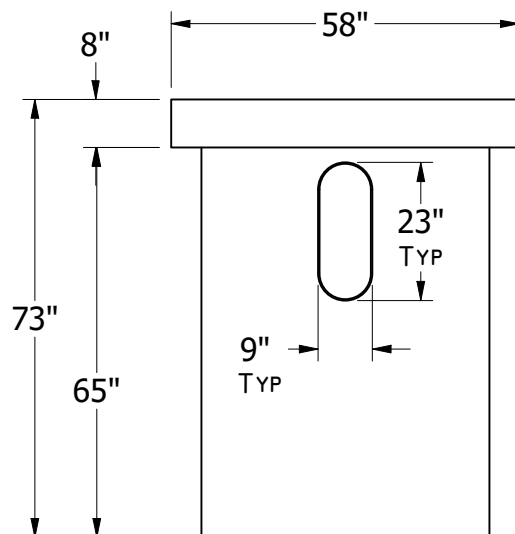

LEFT VIEW

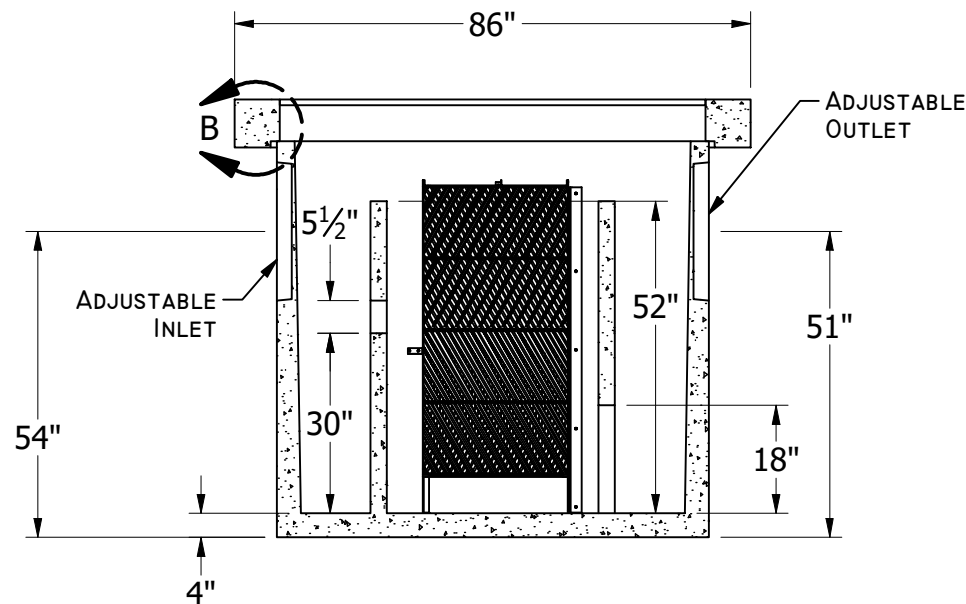

FRONT SECTIONAL VIEW