

GENERAL NOTES:

- TOTAL WEIGHT: 30,930LB
- CONCRETE: 28 DAY COMPRESSIVE STRENGTH FC: 4500PSI
- REBAR: #4 ASTM A-615 GRADE 60
- MESH: ASTM A-185 GRADE 88
- DESIGN: ASTM C-857 "MINIMUM STRUCTURAL DESIGN LOADING FOR UNDERGROUND PRECAST CONCRETE UTILITY STRUCTURES"
- LOADS: H-20 TRUCK WHEEL WITH 30% IMPACT PER AASHTO
- REINFORCING PLACEMENT: 4X4 - 4GUAGE THROUGHOUT WITH 2 - #4 BARS ALONG BELL JOINTS
- HATCHES PER DISTRIC SPECIFICATIONS
- JOINT MATERIAL: MEETS FEDERAL SPECIFICATIONS SS-S-00210, AASHTO M-1988 AND ASTM C990
- TRAFFIC RATED RISERS AS NEEDED

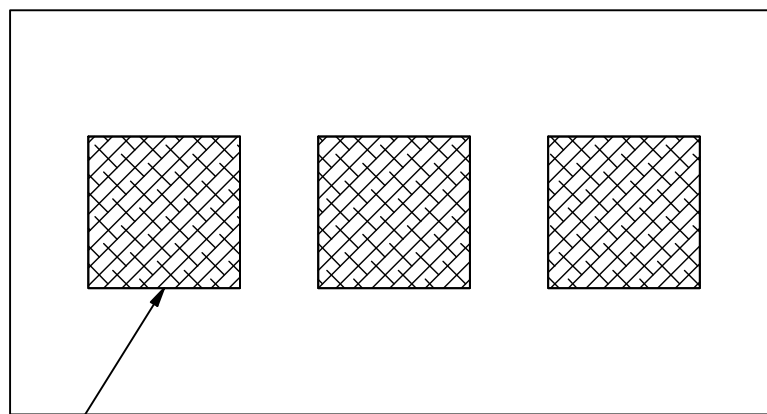

HATCHES PER DIST. SPEC.

OPTIONAL LID

WEIGHT 9,374LB

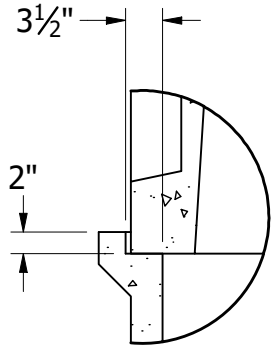

DETAIL C
 DIMENSIONS TYP

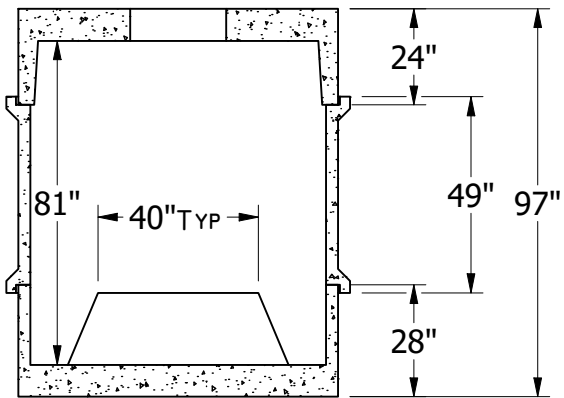
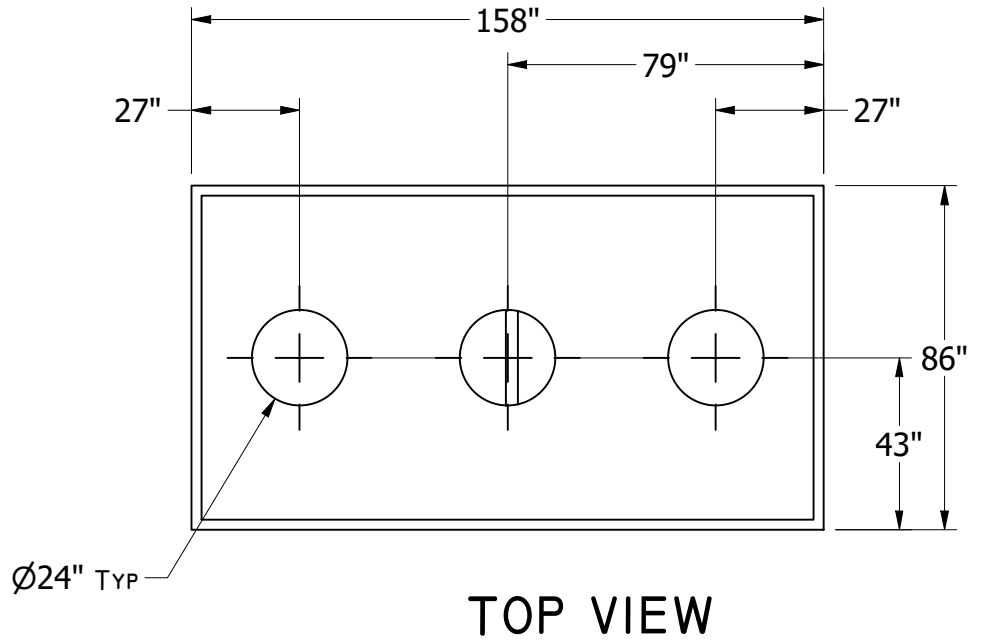

LEFT SECTIONAL VIEW
 SECTION B-B

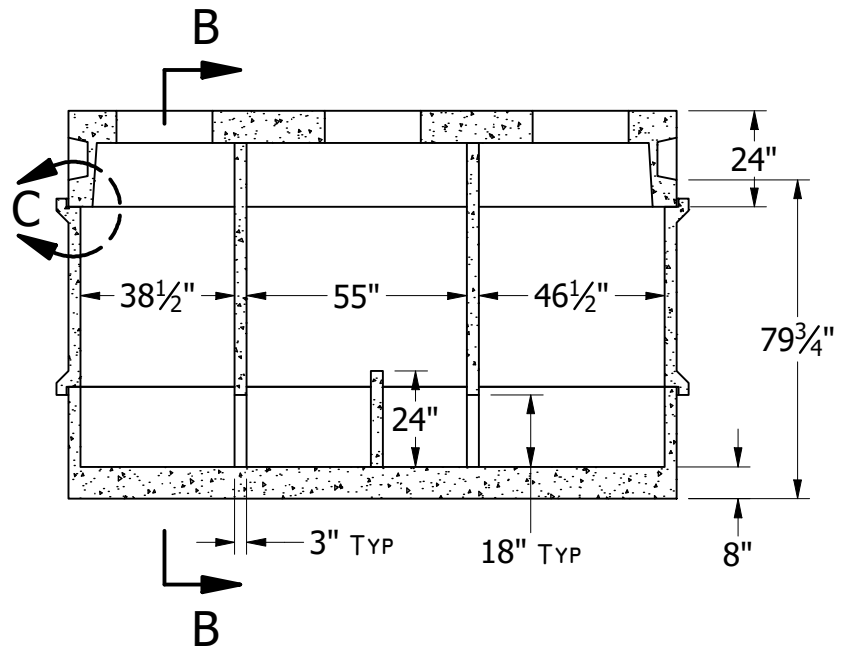

FRONT SECTIONAL VIEW