

19604 67TH AVE NE ARLINGTON, WA 98223  
(360) 435-5531 WWW.CUZCONCRETE.COM

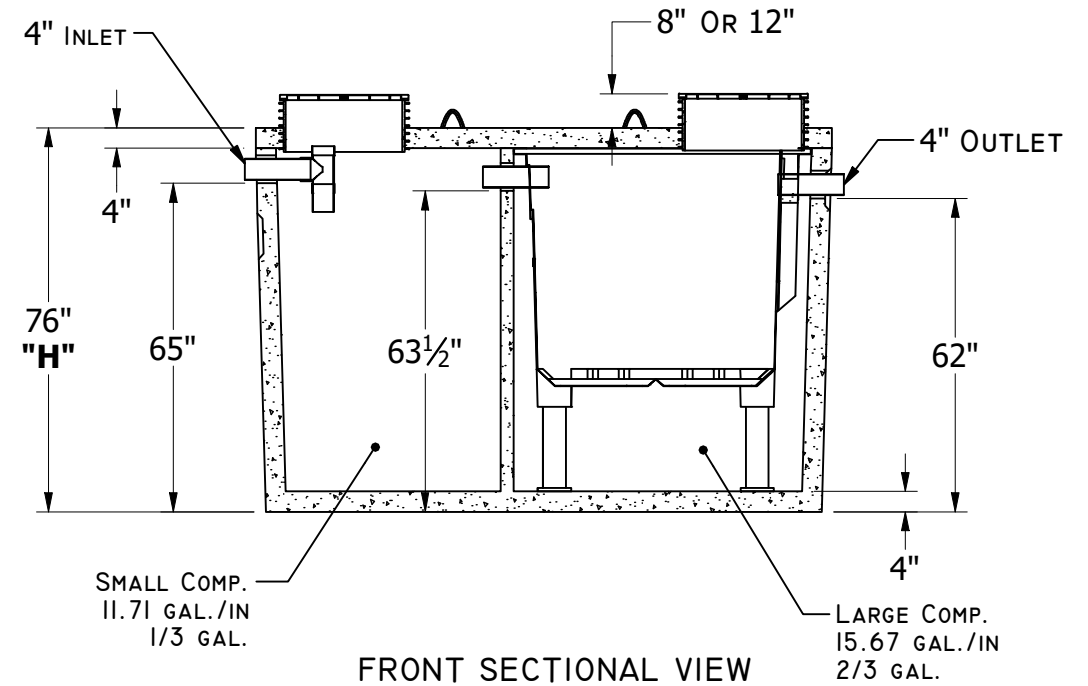
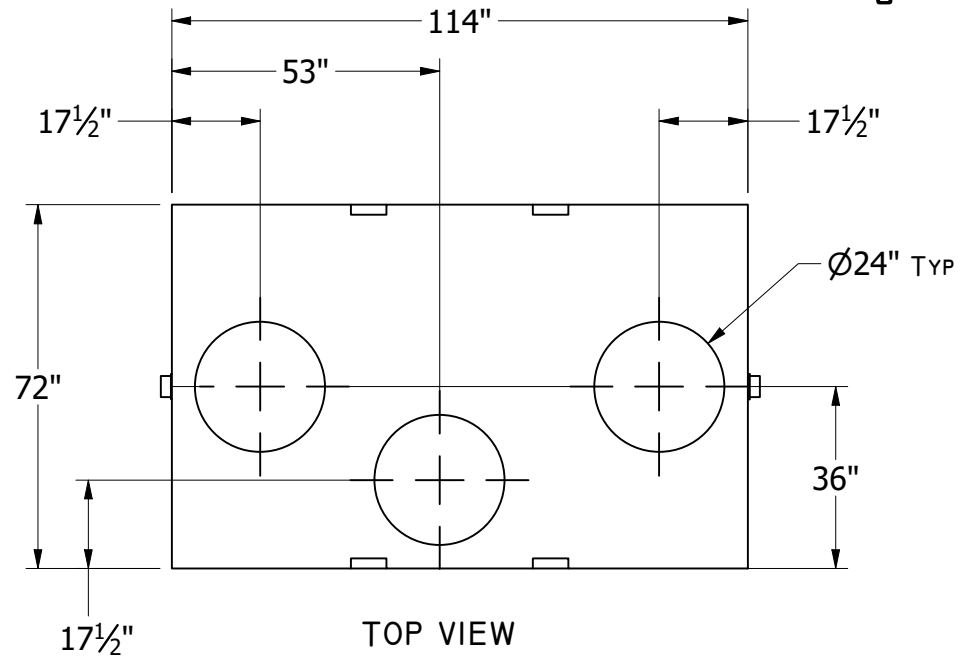
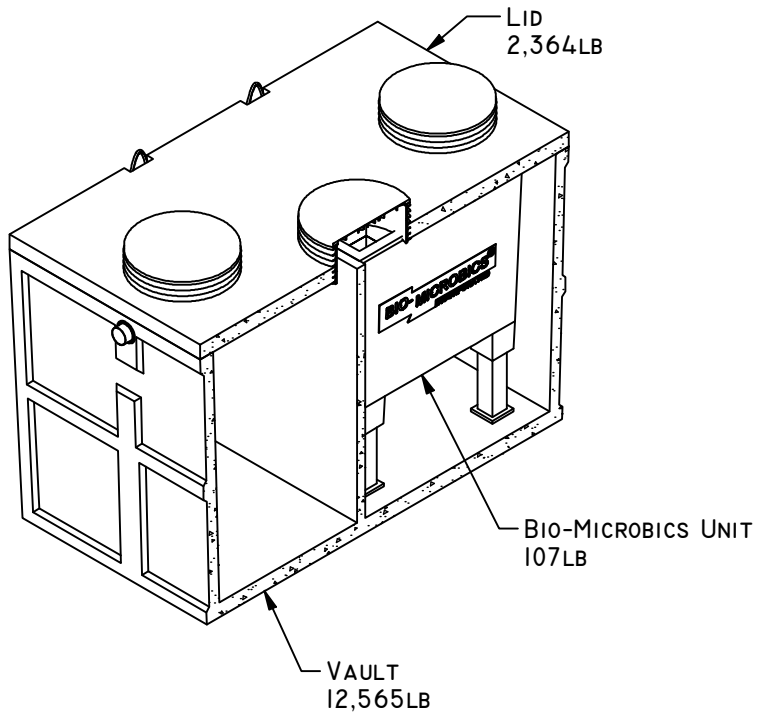

**GENERAL NOTES:**

- TOTAL WEIGHT: 15,126LB
- IF H2O TRAFFIC LID IS INSTALLED HEIGHT (H) IS RAISED 4IN
- CONCRETE 28 DAY COMPRESSIVE STRENGTH FC: 4000PSI
- REBAR #4 ASTM A-615 GRADE 60
- DL: 36IN EARTH COVER
- LL: 25 SNOW
- SOILS: 2000PSI
- WATER PRESSURE: 62.4PSF
- FLEXIBLE PIPE ADAPTER PRESS SEAL 4IN CAST-A-STEEL
- JOINT MATERIAL MEETS FEDERAL SPECS. SS-S-002I
- RISERS AS REQUIRED