

GREASE INTERCEPTOR (1000 - 3000 gal.)

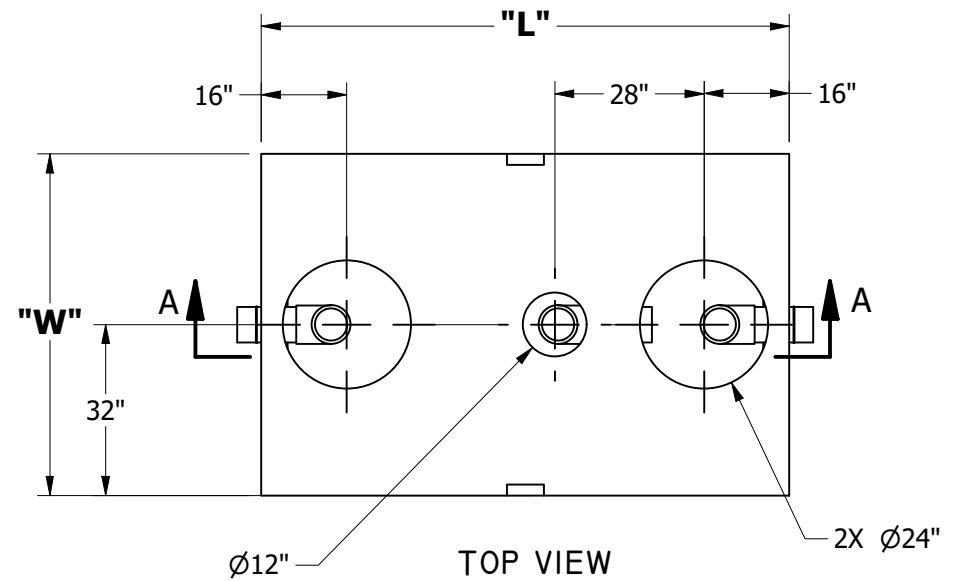
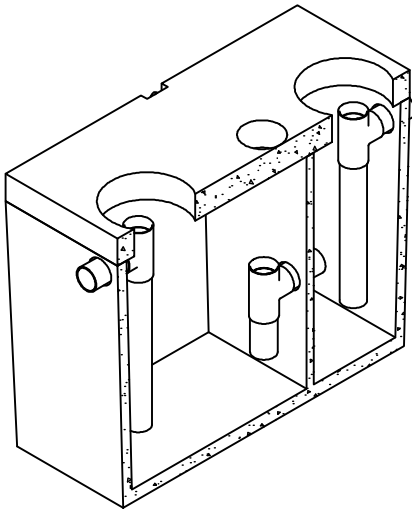

	Weight (lb)	SC (Gal./in)	LC (Gal./in)	L	W	H	I	O
1000 Gal.	10898	7.15	14.31	99	64	69	53	50
1250 Gal.	11972	6.73	13.46	99	64	80	64	61
1500 Gal.	15324	9.17	18.33	114	72	80	64	61
1750 Gal.	15746	8.93	17.86	114	72	86	69	66
3000 Gal.	26798	14.87	29.75	151	86	96	75	72

8" H-20 TRAFFIC LID

GENERAL NOTES:

- ALL DIMENSIONS IN INCHES
- CONCRETE 28 DAY COMPRESSIVE STRENGTH F_c : 4000psi
- REBAR #4 ASTM A-615 GRADE 60
- DL: 36in EARTH COVER
- LL: 25 SNOW
- SOILS: 2000psi
- WATER PRESSURE: 62.4psf
- FLEXIBLE PIPE ADAPTER PRESS SEAL 4in CAST-A-STEEL
- JOINT MATERIAL MEETS FEDERAL SPECS. SS-S-0021
- RISERS AS REQUIRED
- H-20 LOAD

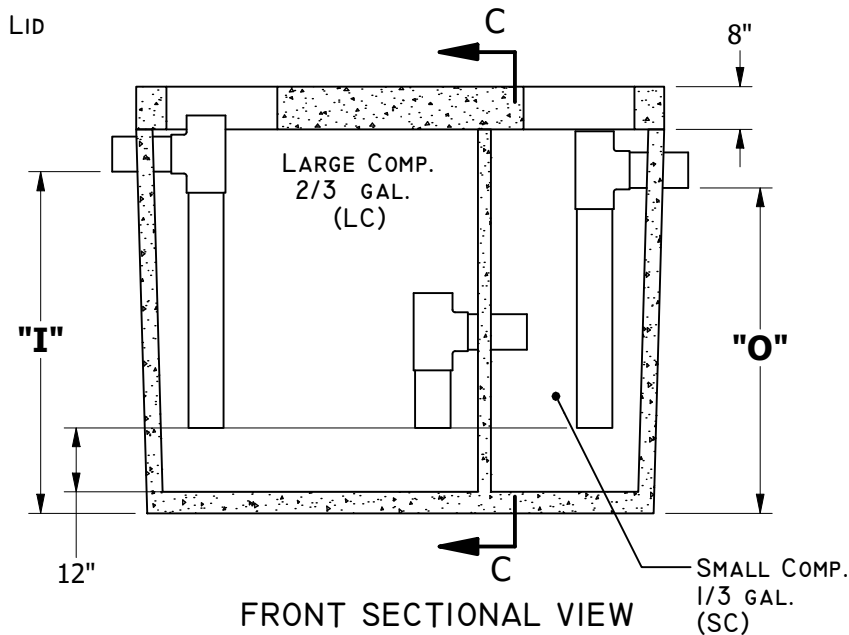
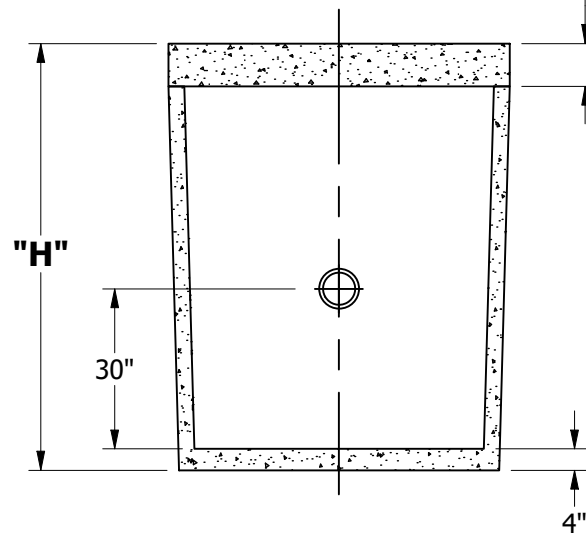

RIGHT SECTIONAL VIEW
SECTION C-C

FRONT SECTIONAL VIEW