

TOP VIEW

	Weight (lb)	Gal./in	L	W	H	I	O
1000 Gal.	8989	21.89	99	64	65	54	51
1250 Gal.	10053	22.77	99	64	76	65	62
1750 Gal.	13184	26.89	114	72	82	70	67

FROM NIBBLER TANK

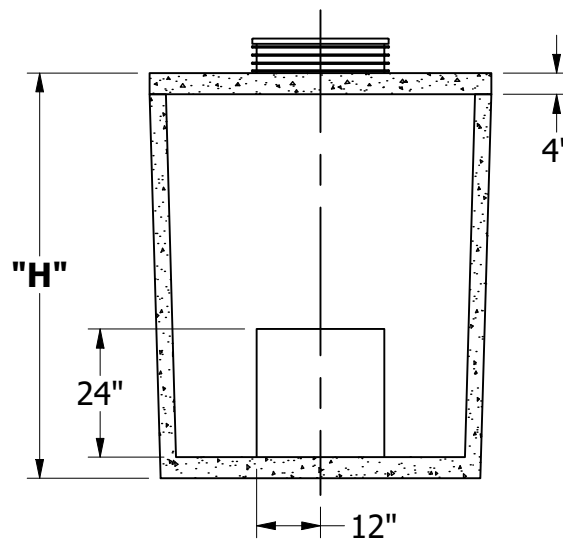

RIGHT SECTIONAL VIEW  
SECTION F-F

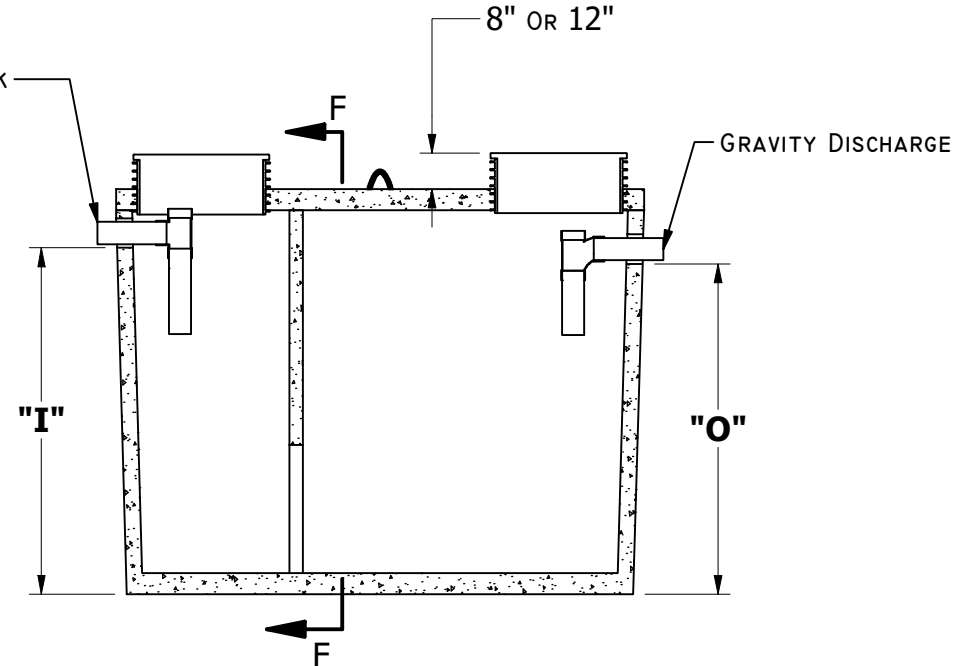

FRONT SECTIONAL VIEW

**GENERAL NOTES:**

- IF H2O TRAFFIC LID IS INSTALLED HEIGHT (H) IS RAISED 4IN
- CONCRETE 28 DAY COMPRESSIVE STRENGTH FC: 4000PSI
- REBAR #4 ASTM A-615 GRADE 60
- DL: 36IN EARTH COVER
- LL: 25 SNOW
- SOILS: 2000PSI
- WATER PRESSURE: 62.4PSF
- FLEXIBLE PIPE ADAPTER PRESS SEAL 4IN CAST-A-STEEL
- JOINT MATERIAL MEETS FEDERAL SPECS. SS-S-002I
- RISERS AS REQUIRED