

2X USF FAB 30" X 42" ALUM. HATCH  
(PER AQUA TEST)

TOP VIEW

**GENERAL NOTES:**

- GALLONS PER INCH: 27.32
- WEIGHT: 12,348LB
- ALL DIMENSIONS IN INCHES
- CONCRETE 28 DAY COMPRESSIVE STRENGTH FC: 4000PSI
- REBAR #4 ASTM A-615 GRADE 60
- DL: 36IN EARTH COVER
- LL: 25 SNOW
- SOILS: 2000PSI
- WATER PRESSURE: 62.4PSF
- FLEXIBLE PIPE ADAPTER PRESS SEAL 4IN CAST-A-STEEL
- JOINT MATERIAL MEETS FEDERAL SPECS. SS-S-002I
- RISERS AS REQUIRED

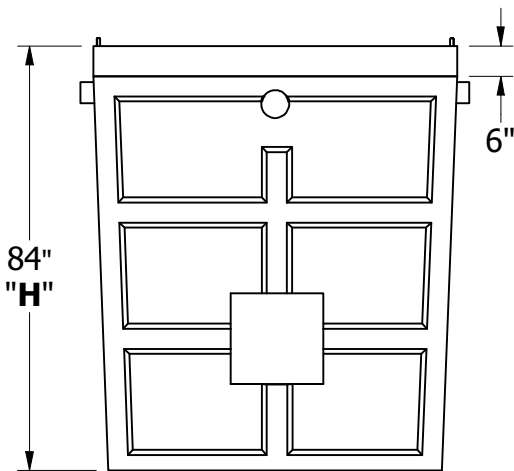

RIGHT VIEW

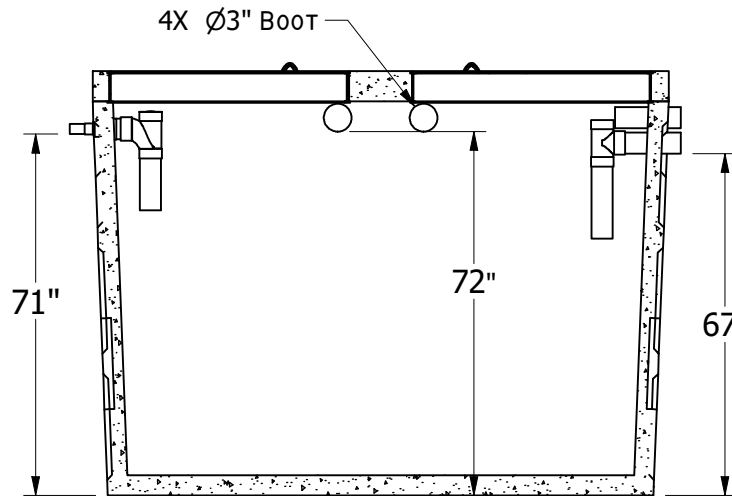

FRONT SECTIONAL VIEW

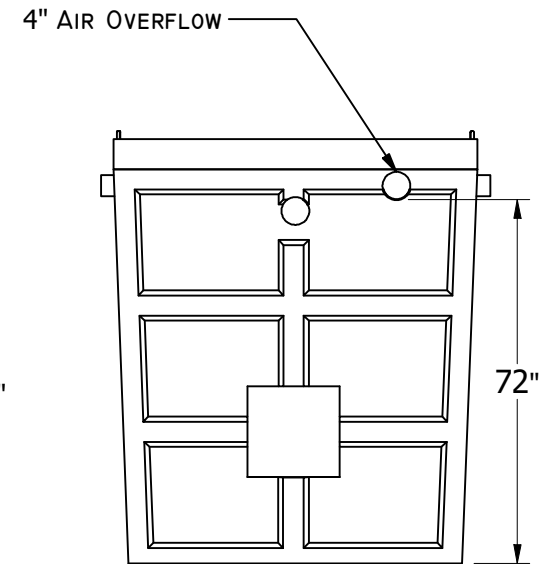

LEFT VIEW