

TOP VIEW

DDC Dimensions					
	L	W	H	Lid Weight (lb)	Base Weight (lb)
675	90	68	76	3096	12568
676	90	68	88	4413	19834

GENERAL NOTES:

- CONCRETE: 28 DAY COMPRESSIVE STRENGTH F'C: 4000Psi
- REBAR: #4 ASTM A-615 GRADE 80
- MESH: ASTM A-185 GRADE 88
- DESIGN: ASTM C-857 MINIMUM STRUCTURAL DESIGN LOADING FOR UNDERGROUND PRECAST CONCRETE UTILITY STRUCTURES
- LOADS: H-20 TRUCK WHEEL w/ 30% IMPACT PER AASHTO
- REINFORCEMENT PLATE: 4X4/4 GAUGE THROUGHOUT w/ 2 - #4 BARS ALONG BELL JOINTS
- JOINT MATERIAL: MEETS FEDERAL SPECS. SS-S-00210, AASHTO M-1988 AND ASTM C990
- HATCHES PER DISTRICT SPECIFICATIONS
- WEIGHT DOES NOT INCLUDE HATCH

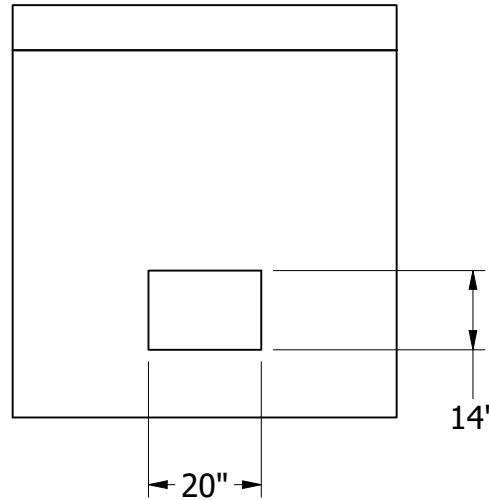

RIGHT VIEW

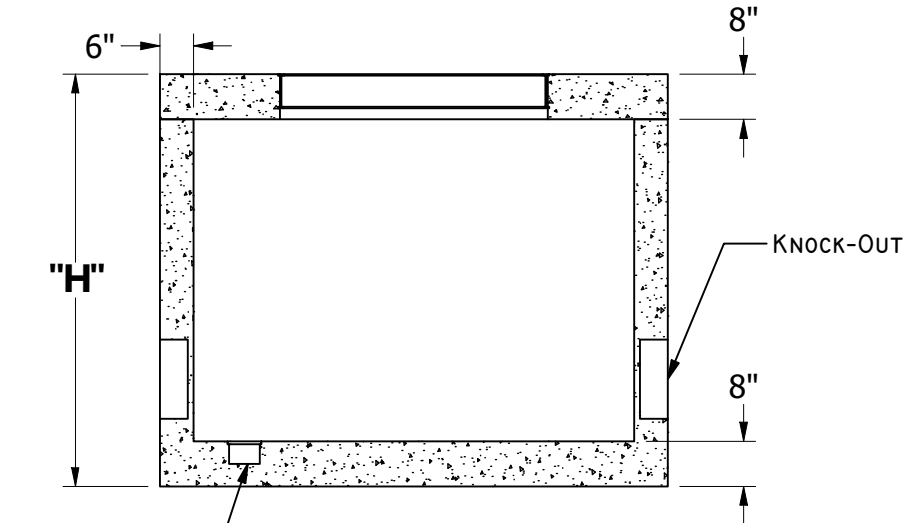

FRONT SECTIONAL VIEW