

19604 67TH AVE NE ARLINGTON, WA 98223
 (360) 435-5531 WWW.CUZCONCRETE.COM

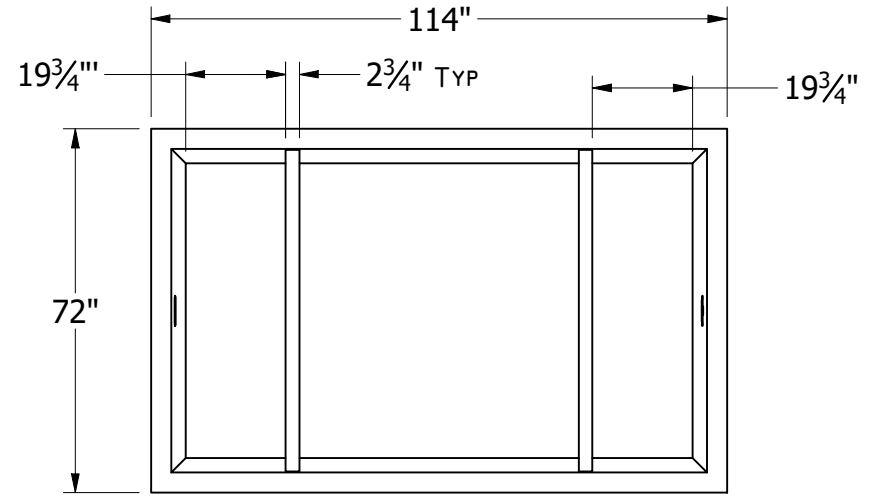
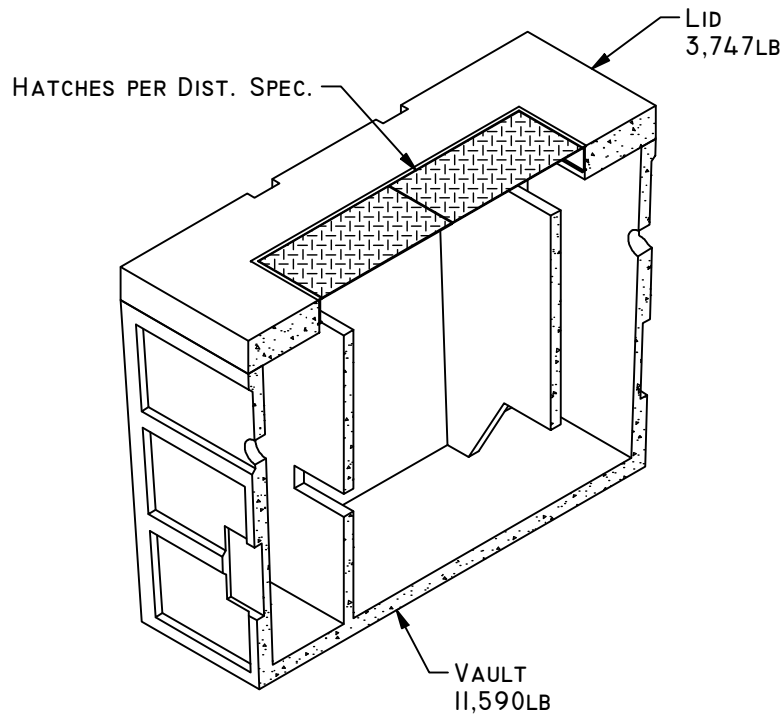

TOP VIEW
 LID OMITTED FOR VISIBILITY

GENERAL NOTES:

- APPROX. WEIGHT:
- CONCRETE: 28 DAY COMPRESSIVE STRENGTH FC: 4500PSI
- REBAR: #4 ASTM A-615 GRADE 60
- MESH: ASTM A-185 GRADE 88
- DESIGN: ASTM C-857 "MINIMUM STRUCTURAL DESIGN LOADING FOR UNDERGROUND PRECAST CONCRETE UTILITY STRUCTURES"
- LOADS: H-20 TRUCK WHEEL WITH 30% IMPACT PER AASHTO
- REINFORCING PLACEMENT: 4X4 - 4 GAUGE THROUGHOUT WITH 2 - #4 BARS ALONG BELL JOINTS
- HATCHES PER DISTRICT SPECIFICATIONS
- JOINT MATERIAL: MEETS FEDERAL SPECIFICATIONS SS-S-00210, AASHTO M-1988 AND ASTM C990
- TRAFFIC RATED RISERS AS NEEDED

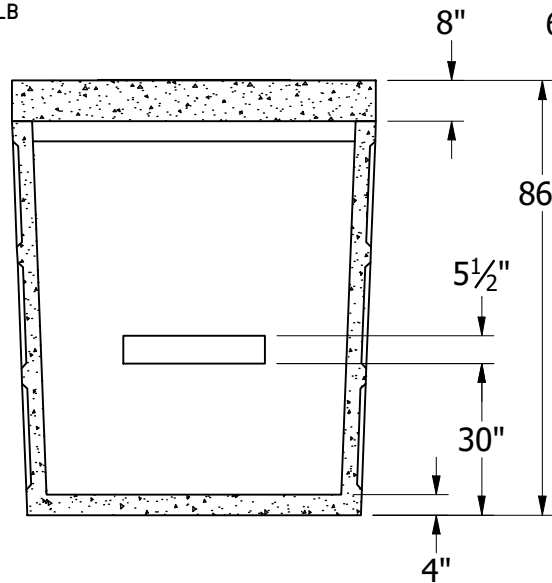

RIGHT SECTIONAL VIEW
 SECTION B-B

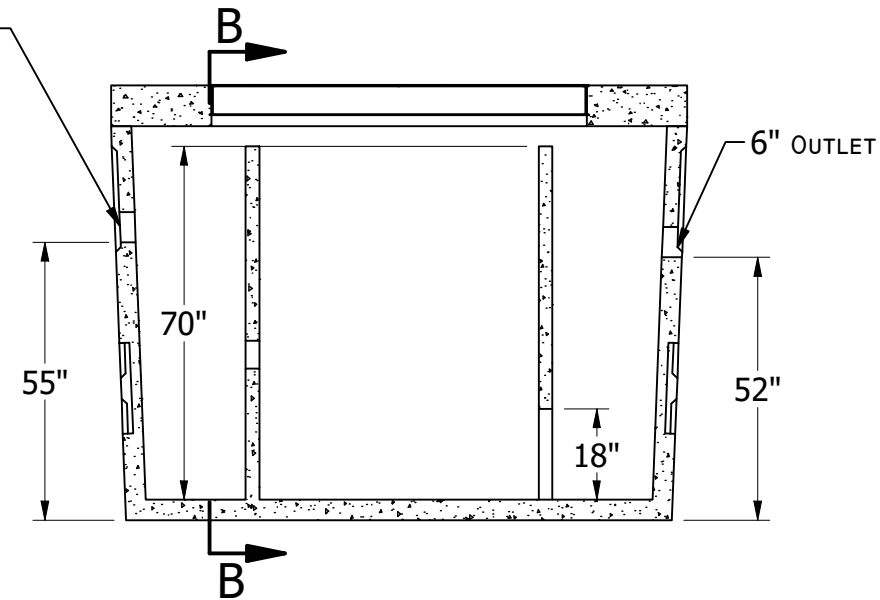

FRONT SECTIONAL VIEW